

Order no.: 930218

ZIG-A connector 8-40 M8, heavy-duty

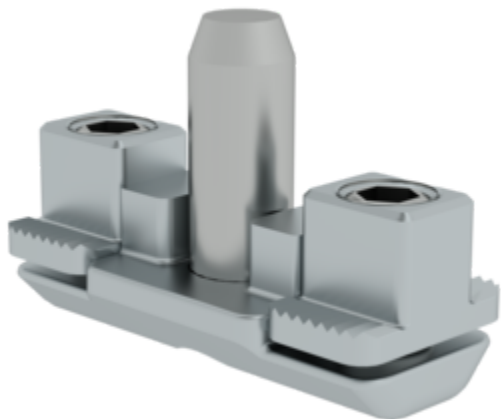

Specification

Material Stahl verzinkt	Weight/piece 46 g	Groove size 8 mm	ISO thread M8	Dimension A 17 mm
Dimension B 39 mm	Dimension C 25 mm	Business division MUNK Profiltechnik	Order no. 930218	

Facts

- Profile connector with force-fit connection
- One-sided design: No notching of surface elements necessary.
- Straightforward application, minimal processing effort
- Infinitely variable adjustability, subsequent adjustment possible
- Durable and reliable construction
- Optimised for quick assembly

Description

Single-sided force connector without notching surface elements! The MUNK Profiltechnik ZIG-A connector 8-40 M8 is the intelligent solution for frame constructions with panels – the single-sided design eliminates the need for time-consuming cut-outs and enables continuous surface fastenings.

Revolutionary single-sided design

- No notching necessary: Panels, sheets or glazing can be fastened continuously, as the connector is only accessible from one side.
- Reinforced construction: 46 g weight (31% heavier than standard ZIG) for higher load-bearing capacity.

- Optimised dimensions: 17×39×25 mm – longer contact surface for better force distribution.
- 8 mm T-slots: Universal for all MUNK 40 mm and 80 mm profiles

Easy to install for closed frames

No surface interruptions: Ideal for protective and test enclosures where panels or glazing are to be installed continuously. Uncomplicated application: Despite one-sided accessibility, minimal processing effort and infinitely variable readjustability.

Reinforced construction for continuous load

The heavy-duty version is specially designed for stressed connections that have to transmit high forces continuously – 31% more material for 31% more safety.

Typical areas of application

- Protective and test enclosures: Continuous glazing without connector interruptions.
- Machine enclosures: Closed panel surfaces with force-fit frame connections.
- Safety partitions: Seamless protective walls with stable profile connections.
- Cleanroom constructions: Smooth surfaces without disruptive connecting elements.

Information on sustainability criteria

- Corporate certification: ISO 9001
- Corporate certification: ISO 14001
- Corporate certification: EN 1090
- Corporate certification: EcoVadis
- RoHS
- REACH
- The MUNK Group complies with a Code of Conduct
- The Supply Chain Act does not apply due to our size

- The materials used are listed in the technical specification
- Resource-saving production: own photovoltaic systems
- Energy-efficient consumption during production: LED lighting
- Repairability, durability and quality: 15-year warranty on series products made in Germany
- Recyclability: Our products are mostly made of aluminium, steel or wood and can be fed directly into the recycling process.
- Socially acceptable working conditions in production: fair wages, gender equality
- Economical and recyclable packaging: no use of polystyrene, predominantly use of wood and cardboard, small amounts of plastic
- No health hazards for the users

More product pictures



Corporate certifications

Standards for quality and sustainability

